

**TECHRIDER  
STILL UND DUNKEL  
AUDIOVISUAL PERFORMANCE**

LIVE EDITING AND MUSIC, STEREO SOUND, 45 - 60 MINUTES  
TWO-CHANNEL HD-PROJECTION, BLACK & WHITE

**REQUIREMENTS (AUDIO)**

PROFESSIONAL PA SYSTEM

- CLEAR SOUNDING, FULL RANGE PA WITH SUBWOOFER (WE EXPERIENCED GOOD SOUND WITH SYSTEMS SUCH AS: KLING & FREITAG CA1001 WITH SW115D-XO, L-ACOUSTICS 12XT WITH SB18)
- 2 MONITORS (DEPENDING ON PA POSITION AND THE DIMENSION OF THE ROOM), VOLUME ADJUSTABLE ON STAGE

1 MIXING BOARD

- WITH 3-BAND EQ (E.G. MACKIE 1202 OR SIMILAR)
- STEREO INPUT 1: JACK (6.3 MM)
- STEREO INPUT 2: CINCH
- IF DIFFERENT PERFORMANCES IN A ROW: FREE STEREO INPUTS AS ABOVE

2 CABLES (2X STEREO SIGNAL)

- 2X JACK (6.3 MM) CONNECTING AUDIO INTERFACE WITH MIXER ON STAGE
- 1X JACK (STEREO, 3.5MM) TO CINCH (2X MONO)

1 STAGE TABLE (FOR ALL 3 ARTISTS, VIDEO & AUDIO)

- IF DIFFERENT PERFORMANCES IN A ROW: MIN. 2 QM SPACE ON TABLE
- PREFERRED: ALUMINIUM STAGE TABLE DIMENSION 2M X 1M HEIGHT: 1M; OR SIMILAR MEASURES

1 POWER CABLE

- SUPPLY VOLTAGE 220-230 V

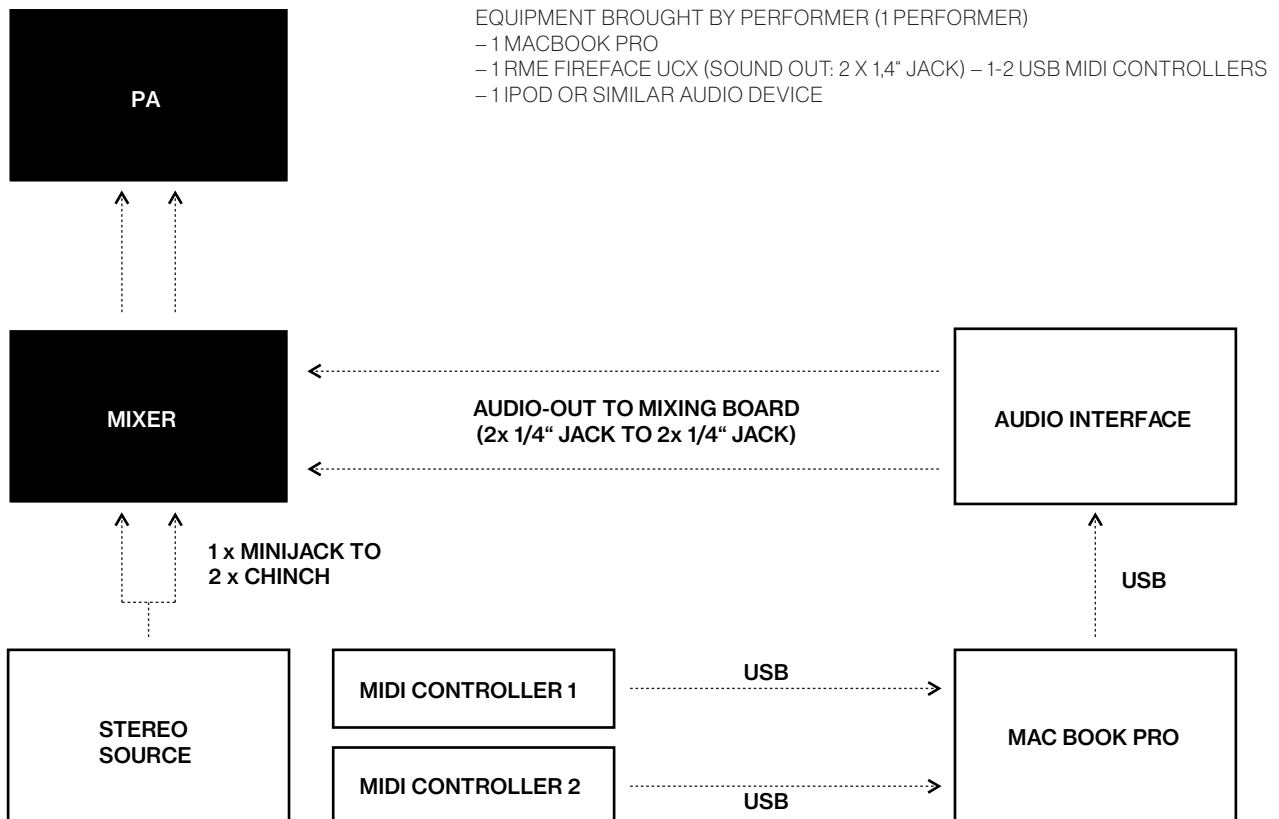

**TECHRIDER  
STILL UND DUNKEL  
AUDIOVISUAL PERFORMANCE**

---

**REQUIREMENTS (VIDEO)**

---

- 2 BEAMERS
    - TWO IDENTICAL MODELS WITH THE SAME AMOUNT OF LAMP-HOURS
    - FULL HD PROJECTORS, MIN. 1920X1080 PIXELS
    - 2 MOUNTED HDMI CABLES FROM THE BEAMER TO WORKSPACE OF THE VJS
  - WORKPLACE (SEE: STAGE TABLE AUDIO)
    - 1 TABLE (ALUMINIUM STAGE TABLE DIMENSION 2M X 1M HEIGHT: 1M; OR SIMILAR DIMENSIONS)
    - IF DIFFERENT PERFORMANCES IN A ROW: MIN. 2QM SPACE ON TABLE
    - THE MAIN SCREEN SHOULD BE VISIBLE FOR ALL THE PERFORMERS;  
IF THIS IS NOT THE CASE, TWO SUPPLEMENTARY MONITOR SCREENS ARE NECESSARY
  - POWER CABLE
    - SUPPLY VOLTAGE 220-230 V
- EQUIPMENT BROUGHT BY PERFORMERS (2 PERFORMERS)
- 2 MACBOOK PRO
  - 2 MIDI INTERFACES VIA USB

**SETUP (STANDARD)**

---

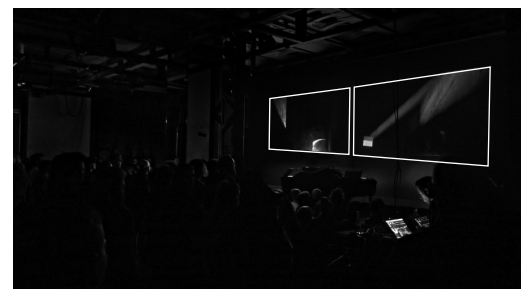
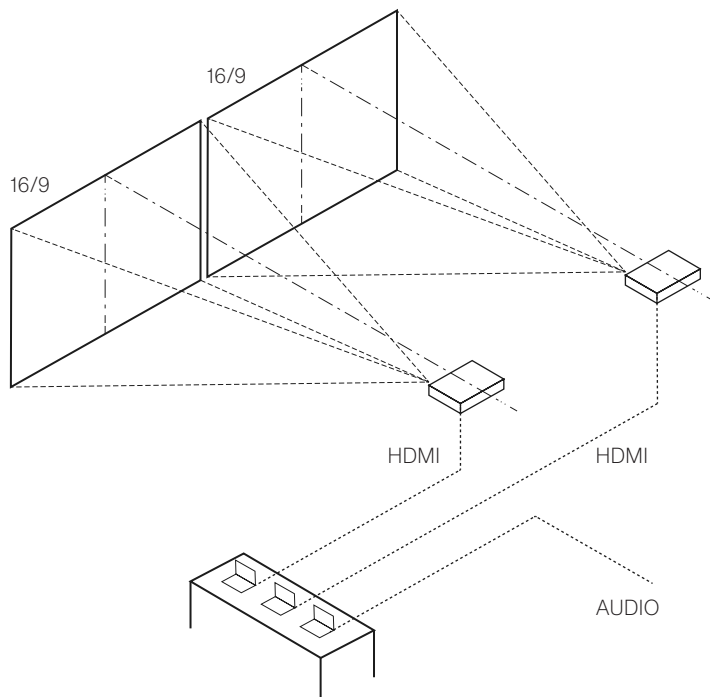

EXAMPLE: INTERNATIONAL FILM  
FESTIVAL ROTTERDAM, 2016

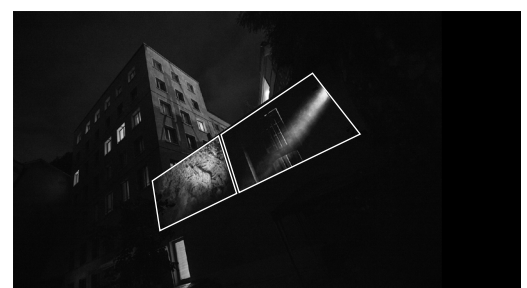

EXAMPLE: BADEN, AUGUST 2017

**TECHRIDER  
STILL UND DUNKEL  
AUDIOVISUAL PERFORMANCE**

---

**SETUP (VARIATIONS)**

---

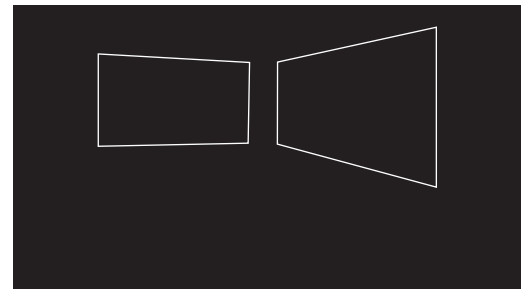
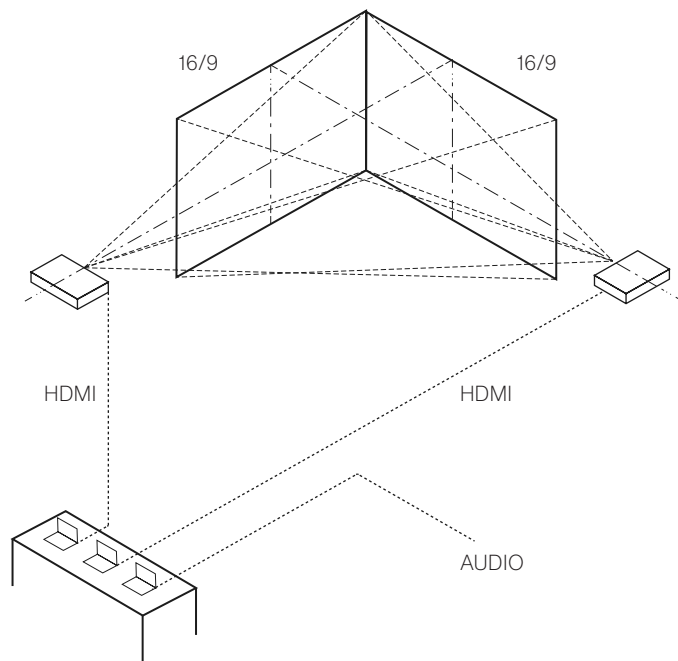

EXAMPLE: INTERNATIONAL SHORTFILM FESTIVAL WINTERTHUR, 2017



EXAMPLE: BINZ39, ZURICH, 2015

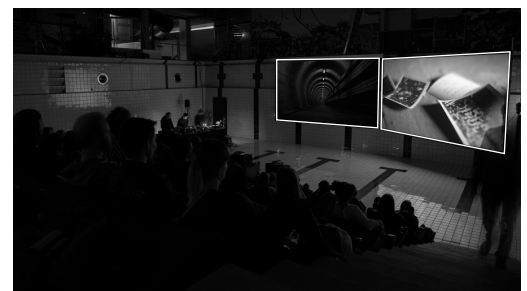
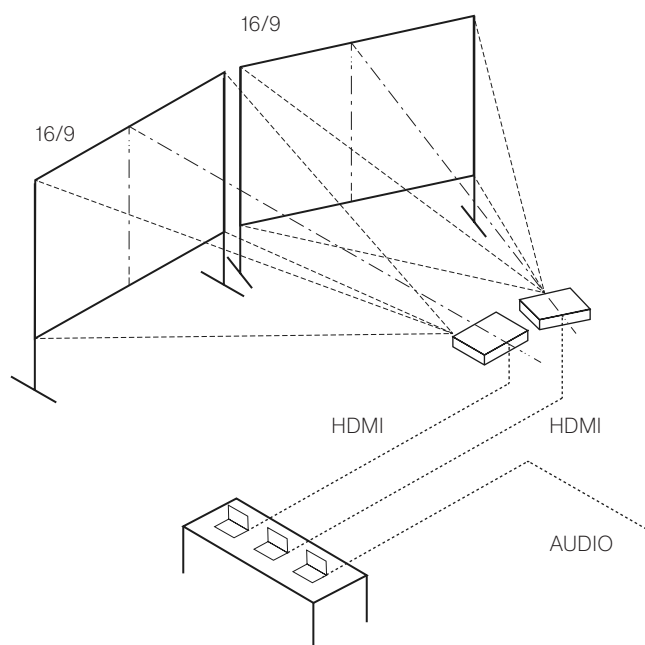

EXAMPLE: NEUBAD LUCERNE, 2016



EXAMPLE: DOKFEST KASSEL, 2013